

# THE RANGE

## MALE ADAPTOR

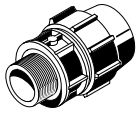

CODE DN  
KRFM From 16-3/8" to 110-4"

## 90° TEE WITH THREADED FEMALE OFFTAKE

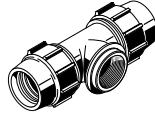

CODE DN  
KTF From 16-1/2"-16 to 110-4"-110

## CLAMP SADDLE WITH METAL STIFFENING

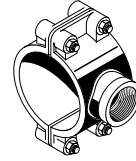

CODE DN  
KPSX From 25 to 160

## FEMALE ADAPTOR

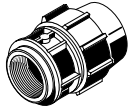

CODE DN  
KRFF From 16-1/2" to 110-4"

## 90° ELBOW



CODE DN  
KG From 16 to 110

## DOUBLE CLAMP SADDLE

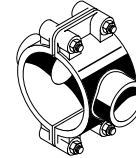

CODE DN  
KPSD From 25 to 160

## COUPLING

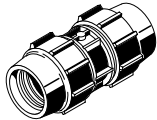

CODE DN  
KMAN From 16 to 110

## 90° ELBOW WITH THREADED FEMALE OFFTAKE



CODE DN  
KGF From 16-1/2" to 110-4"

## DOUBLE CLAMP SADDLE WITH METAL STIFFENING

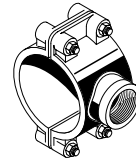

CODE DN  
KPSDX From 25 to 160

## REDUCING COUPLING

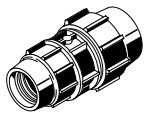

CODE DN  
KR From 20-16 to 110-90

## 90° ELBOW WITH THREADED MALE OFFTAKE

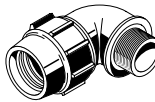

CODE DN  
KGM From 16-3/8" to 110-4"

## NUT

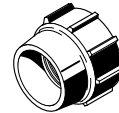

CODE DN  
KGH From 16 to 110

## 90° TEE



CODE DN  
KT From 16 to 110

## ENDCAP



CODE DN  
KTAPPO From 16 to 110

## SPLIT RING

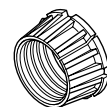

CODE DN  
KPINZA From 16 to 110

## REDUCING 90° TEE



CODE DN  
KTR From 25-20-25 to 110-90-110

## FLANGED JOINT

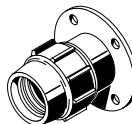

CODE DN  
KRFL From 50-1 1/2" to 160-6"

## THRUST RING



CODE DN  
KANELLO From 16 to 110

## 90° TEE WITH THREADED MALE OFFTAKE



CODE DN  
KTM From 16-1/2"-16 to 110-4"-110

## CLAMP SADDLE

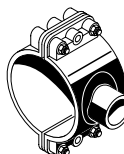

CODE DN  
KPS From 25 to 160

## GASKET



CODE DN  
KORR From 16 to 110

## FOR CLAMP SADDLES

CODE DN  
KORS From 25 to 160

# THE PRODUCT

The ELOPRESS compression fittings are used for potable water and alimentary fluids distribution systems.

Applicable for high, medium and low density PE pipes at a maximum operating temperature of 20°C, the ELOPRESS fittings comply with UNI 9561.

ELOPRESS is suitable for:

- POTABLE WATER DISTRIBUTION SYSTEMS
- CONVEYANCE OF ALIMENTARY FLUIDS
- FIRE PREVENTION NETWORKS
- PRESSURIZED SYSTEMS
- IRRIGATION NETWORKS

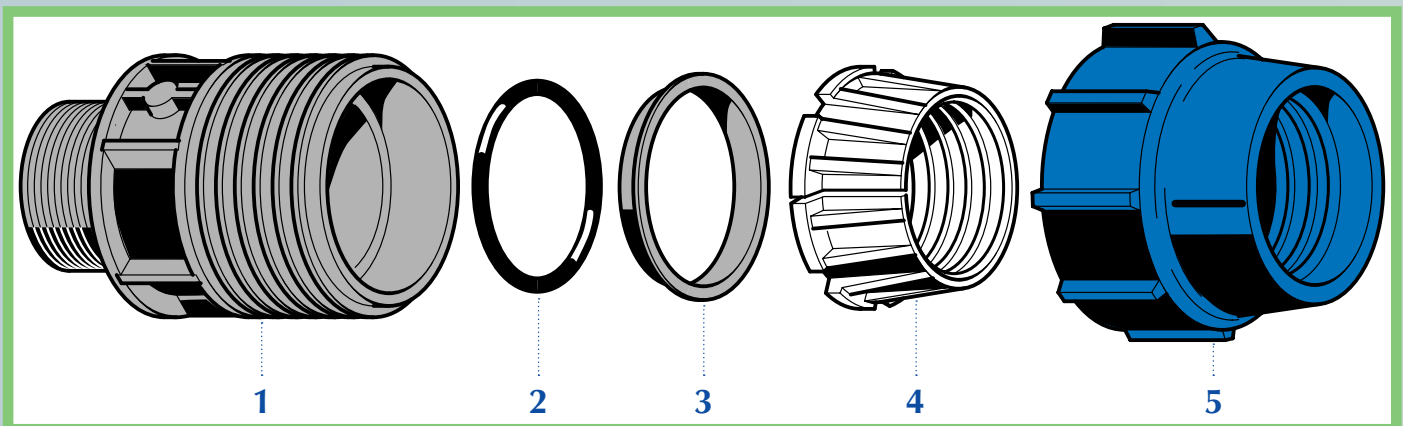

The ELOPRESS compression fittings are mechanical joints from d. 16 mm up to d. 110 mm and are composed as follows:

**1 BODY**

**2 GASKET (O-RING)**

The nitric rubber gasket leans on the pipe surface, guaranteeing a perfect hydraulic seal.)

**3 THRUST RING**

**4 SPLIT RING**

Its conic shape ensures a perfect mechanical seal on the piping system when the nut is tightened to the body.

**5 NUT**

The ELOPRESS product range is completed with a wide selection of clamp saddles from d. 25 to 160 mm. They are available both in normal version as with stainless steel ring. The clamp saddles are composed of two polypropylene parts, held together by bolts and 2 nitric rubber gaskets that ensure a perfect seal. The number of bolts depends on the diameters: 2 bolts for d. 25-50 mm, 4 bolts for d. 63-90 mm and 6 bolts for d. 110-160 mm.

- 1** BOLT AND NUTS
- 2** BASE
- 3** GASKET
- 4** UPPER PART WITH OUTLET
- 5** REINFORCED RING

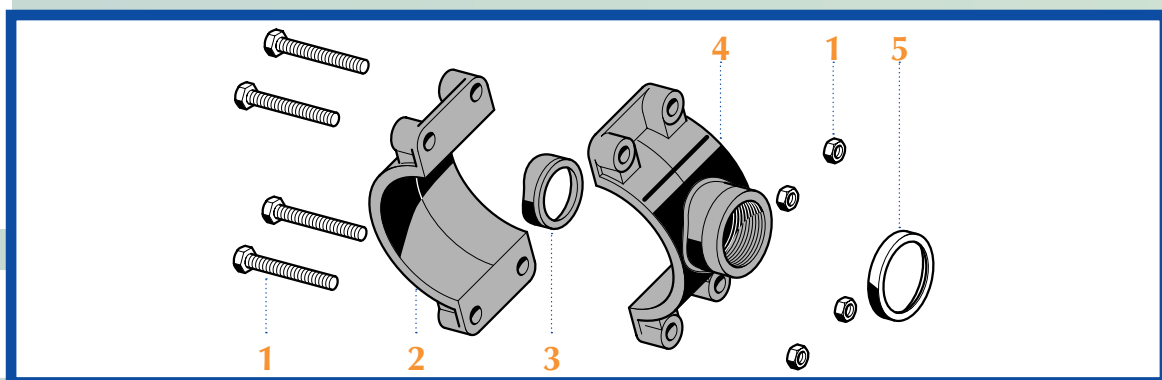

## THE MATERIAL

### NOMINAL PRESSURE AT 20°C

PN16 (16 bars) fittings between Ø 16-63 mm  
 PN10 (10 bars) fittings between Ø 75-110 mm  
 PN10 clamp saddles

### CHARACTERISTICS

**Body:** Black copolymer polypropylene PP-B (Type 2)  
 Max. temperature: 80°C\*

**Nut:** Blue copolymer polypropylene PP-B (Type 2)  
 Max. temperature: 80°C\*

**Gasket:** 75 Shore nitric rubber (NBR)

**Split ring:** White polyacetal

**Reinforced ring:** "AISI 430" stainless steel

\* Without pressure

# INSTRUCTIONS

CUT THE PIPE WITH THE PIPE CUTTER, CHAMFER AND CLEAN THE PIPE BEFORE INSTALLATION!

## COMPRESSION FITTINGS D. 16-63

Unscrew the nut and the split ring.  
Put the pipe through the nut and the split ring- with the conic part facing the nut.

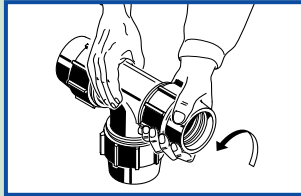

Insert the pipe into the body until it arrives to beat.

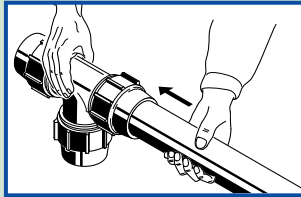

Slide the split ring until it reaches the body of the fitting.

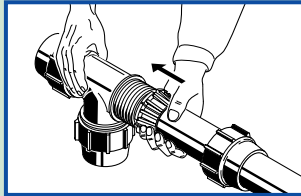

Tighten the nut on the body of the fitting.

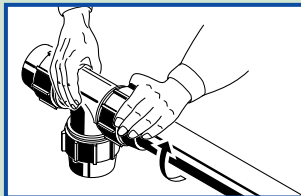

Use a wrench to completely tighten the nut.

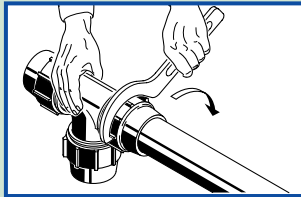

## COMPRESSION FITTINGS D. 75-110

Unscrew the nut, the split ring, the thrust ring and the o-ring.

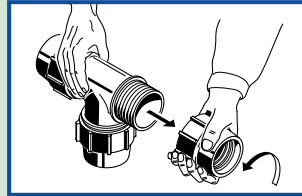

Insert the nut, the thrust ring and the o-ring on the pipe.

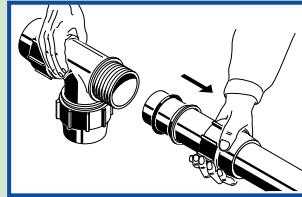

Lubricate the pipe extreme and insert it into the body until beat.  
Push the o-ring and the thrust ring inside of the body.

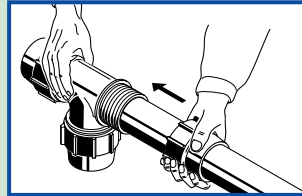

Screw the nut.

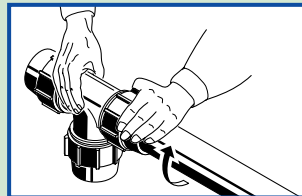

Unscrew the nut from the body.

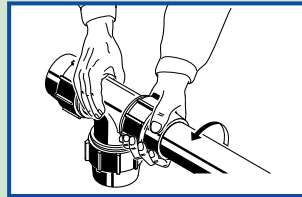

Insert the split ring on the pipe between the nut and the body- with the conic part toward the nut.

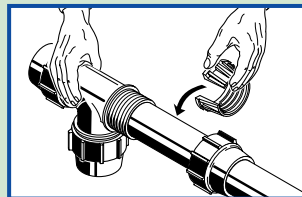

Tighten the nut to the body with a wrench.

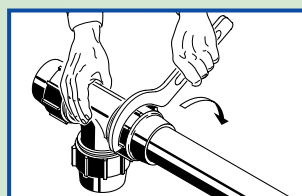

# INSTRUCTIONS

**CUT THE PIPE WITH THE PIPE CUTTER, CHAMFER AND CLEAN THE PIPE BEFORE INSTALLATION!**

## **CLAMP SADDLES D. 25-160:**

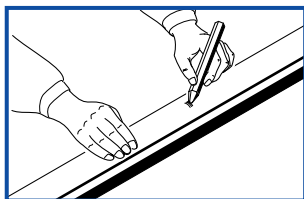

Select the installation point and make sure that the outer surface of the pipe is free of any scratch, cut or other imperfections in the contact area of the gasket.

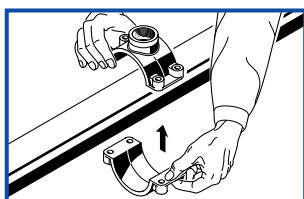

Position the bottom half of the saddle on the previously selected area of the pipe. Connect the top half of the saddle with the bottom part.

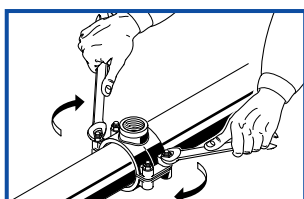

Insert bolts from bottom.  
Tighten the nuts.

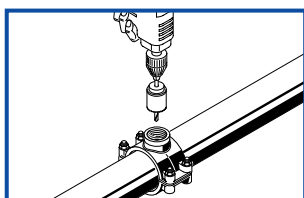

Perforate the pipe. Be careful not to damage the thread of the saddle and the gasket. We recommend to use a spacer to avoid the perforation of the pipe on the other side.

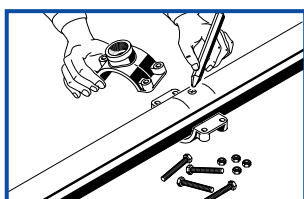

Alternatively, once you fixed the place of the saddle, mark the points which correspond to the position of the saddle with a white felt pen.

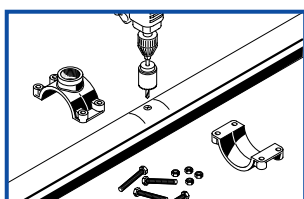

Perforate the pipe and remove PE shaving from inside.

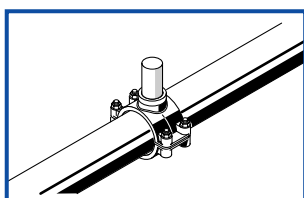

Assemble the clamp saddle according to the previous position marks. Use a pin to keep the outlet in axis with the hole.



**GECO QUALITY SYSTEM CERTIFICATION** comply with **INTERNATIONAL STANDARDS ISO 9001**. This certification is the right recognition of the continuous efforts made by the company in order to ensure constant quality and compliance with the standards over the whole production process.

**GECO  
SYSTEM**

Via Magenta, 43 - 21015 Lonate Pozzolo - Italy  
 Tel. +39 0331 302975 - Fax +39 0331 302965  
 E-Mail: [info@gecosystem.com](mailto:info@gecosystem.com) - Web Site: <http://www.gecosystem.com>

# ELOPRESS

PP COMPRESSION FITTINGS



**GECO**  
**SYSTEM**

## THE FIRM



can plan in real time thanks to perfect integration of company functions.

GECO System is an important European actor; our products have been installed around the world, and our company quality system has been certified to comply with ISO 9002 since 1992, and is

GECO System was set up in the mid-70's. Right from the start, our core business was moulding pipe fittings made of thermoplastic material for a wide range of uses, from sanitary installations to water and gas pipe lines. Two modern production plants - located in a highly industrial area - produce over 22,000,000 top quality PPR, PVC, PB, and HDPE pipe fittings, using fully automatic and modern equipment, connected to the company computer system.

World markets are posing



increasing demands on companies during this end-of-the-millennium.

Technology is making the goals of producing more and producing more quickly more and more compatible with each other.

Our customers can thus count on the care taken in fully automatic production, and also on timely delivery, which we

IQNET/CISQ certified.

Technical capacity and high throughput are supported by effective after-sales and professional training services which make us a reliable partner for all our customers.